



## Condensing units

CONDENCIAT CL

*Outdoor condensing unit  
for direct expansion applications  
Variable speed propeller fan*



Cooling capacity: 5.2 to 18.6 kW



Cooling



### USE

The **CL Condenciat** units with air-cooled condensers are designed for small sized refrigerating installations. They are particularly suitable for industrial process, small shops, offices, restaurants.

Installed outdoor (propeller fan), they are directly connected, through refrigerant piping, to a direct water or air expansion exchanger.

They can be associated with a wide variety of indoor exchangers:

- Air handling box coil

- Separate water cooling evaporator, EXEL, HF, FYN types
- Integrated into a precision air handling cabinet such as Micro 2000 or Expair.
- Any type of terminal unit of equivalent capacity

We remind you that the air handling units' control should be studied with care when choosing the direct expansion solution.

### DESCRIPTION

#### Standard equipment

- Scroll compressor
- Crankcase heater on 50 - 65 - 75 models
- Air-cooled condenser, copper tubes coil, aluminium fins
- Direct drive propeller fan(s) - (1 or 2 according to the model)
- Year-round operation
- Condensing pressure control through fan speed variation (pressure sensor)
- Refrigerant connections (FLARE connectors)

- Operation for outside temperatures between: - 15°C and + 45°C
- Casing in "ABS" synthesis material, recyclable and UV stabilised, light and sturdy  
Its exclusive and high-quality design facilitates its integration in the field of vision.
- Conforms to norms and directives :
  - CEM 89/336/CEE
  - BT 93/68/CEE
  - DEP 97/23/CEE

#### Optional equipment

- Antivibration mounts
- Wall support (models 20, 28, 35)
- Crankcase heater on models 20, 28, 35
- Thermostatic expansion kit



## QUICK SELECTION

### CONDENCIAT CL

CL	Number of circuits	Number of compressors	Cooling capacity (KW)	Power consumption (KW)
20	1	1	5.2	1.8
28	1	1	6.8	2.6
35	1	1	8.6	3.5
50	1	1	12.1	4
65	1	1	14.5	4.9
75	1	1	18.6	6.8

CL refrigerant fluid R410A  
 Evaporation temperature +2°C  
 DB air temperature at condenser = +35°C

## CONNECTION

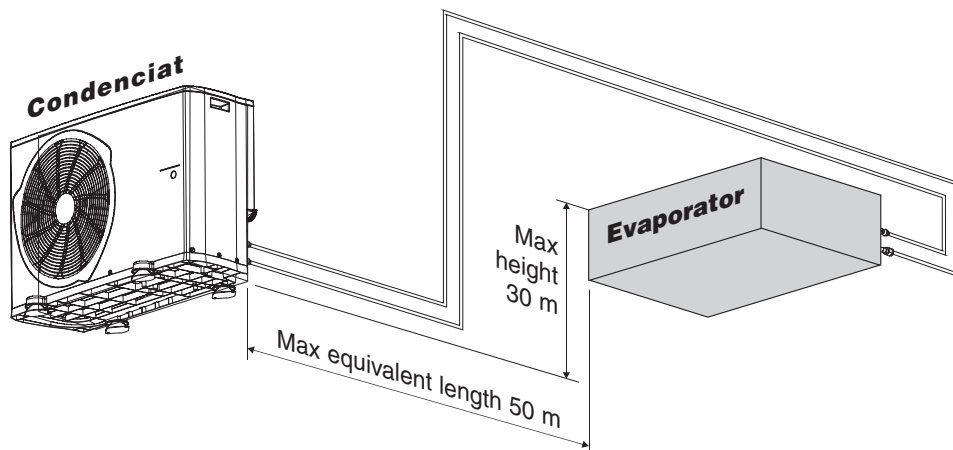

### Equivalent length for 90° angle

Tube diameter (inches)	1/4"	3/8"	1/2"	5/8"	3/4"	7/8"
Equivalent length (m)	0.25	0.35	0.45	0.55	0.65	0.7

All the network accessories must be taken into account



# Condensing units

CONDENCIAT CL

## COOLING CAPACITIES

CL		Condenser inlet temperature (°C)									
		25		30		35		40		45	
		Pf kW	Pa kW	Pf kW	Pa kW	Pf kW	Pa kW	Pf kW	Pa kW	Pf kW	Pa kW
20	Evaporating temperature (°C)										
	-2	5.1	1.4	4.8	1.6	4.5	1.8	4.1	2.0	3.8	2.2
	0	5.5	1.5	5.1	1.6	4.8	1.8	4.4	2.1	4.1	2.3
	2	6.0	1.4	5.5	1.6	5.2	1.8	4.8	2.1	4.4	2.3
	4	6.3	1.5	5.9	1.7	5.5	1.9	5.2	2.1	4.8	2.3
	6	6.6	1.5	6.3	1.7	5.9	1.9	5.5	2.1	5.1	2.3
	8	7.1	1.5	6.8	1.7	6.3	1.9	5.9	2.1	5.5	2.3
10	7.6	1.5	7.2	1.7	6.8	1.9	6.3	2.1	5.9	2.3	
28	-2	6.8	2.0	6.4	2.3	5.9	2.6	5.6	2.9	5.1	3.3
	0	7.4	1.9	6.9	2.3	6.4	2.6	5.9	2.9	5.5	3.2
	2	7.9	1.9	7.3	2.3	6.8	2.6	6.3	3.0	5.8	3.3
	4	8.3	2.1	7.8	2.3	7.3	2.6	6.8	2.9	6.3	3.3
	6	8.8	2.1	8.3	2.4	7.8	2.6	7.2	3.0	6.6	3.4
	8	9.5	2.1	8.8	2.4	8.2	2.7	7.7	3.0	7.1	3.4
	10	9.9	2.2	9.3	2.4	8.7	2.7	8.1	3.1	7.6	3.4
35	-2	8.5	2.8	8.0	3.1	7.4	3.5	6.9	3.9	6.4	4.3
	0	9.1	2.8	8.5	3.1	8.0	3.5	7.4	4.0	6.9	4.3
	2	9.7	2.8	9.1	3.2	8.6	3.5	7.9	4.0	7.3	4.4
	4	10.3	2.9	9.7	3.2	9.1	3.6	8.4	4.0	7.7	4.5
	6	11.2	2.8	10.5	3.1	9.6	3.6	9.0	4.0	8.3	4.5
	8	11.6	3.0	10.9	3.3	10.2	3.7	9.5	4.1	8.7	4.6
	10	12.2	3.0	11.5	3.4	10.8	3.8	10.1	4.1	9.3	4.6
50	-2	12.0	3.1	11.3	3.5	10.6	3.9	9.9	4.4	9.0	5.0
	0	12.9	3.1	12.1	3.5	11.4	3.9	10.6	4.4	9.8	5.0
	2	13.6	3.2	12.9	3.6	12.1	4.0	11.3	4.5	10.5	5.0
	4	14.4	3.2	13.7	3.6	12.9	4.0	12.0	4.5	11.1	5.1
	6	15.5	3.2	14.5	3.6	13.7	4.1	12.8	4.5	11.9	5.1
	8	16.5	3.2	15.4	3.7	14.5	4.1	13.6	4.6	12.6	5.1
	10	17.1	3.4	16.3	3.8	15.3	4.2	14.4	4.6	13.4	5.2
65	-2	14.4	3.9	13.6	4.3	12.7	4.7	11.7	5.2	10.8	5.7
	0	15.4	3.9	14.5	4.3	13.6	4.8	12.6	5.3	11.7	5.8
	2	16.7	3.9	15.5	4.4	14.5	4.9	13.5	5.3	12.4	5.9
	4	17.4	4.1	16.4	4.5	15.4	4.9	14.4	5.4	13.4	5.9
	6	18.5	4.1	17.5	4.6	16.4	5.0	15.4	5.5	14.2	6.1
	8	19.9	4.1	18.8	4.5	17.4	5.1	16.3	5.6	15.2	6.1
	10	21.1	4.2	19.6	4.7	18.5	5.2	17.3	5.7	16.1	6.2
75	-2	18.7	5.4	17.5	6.0	16.3	6.6	14.9	7.4	13.5	8.2
	0	19.7	5.6	18.4	6.2	17.4	6.7	16.0	7.5	14.7	8.2
	2	21.2	5.6	19.9	6.2	18.6	6.8	17.1	7.6	15.8	8.3
	4	22.5	5.7	21.1	6.3	19.7	7.0	18.4	7.6	16.7	8.5
	6	23.9	5.8	22.4	6.4	20.9	7.1	19.3	7.9	18.0	8.5
	8	26.0	5.7	23.8	6.5	22.2	7.2	20.5	7.9	18.8	8.8
	10	26.7	6.1	25.1	6.7	23.5	7.3	21.8	8.1	19.9	8.9

Pa: total absorbed capacity of the CL unit (compressor + fan + control) Pf: Cooling Capacity



### TECHNICAL CHARACTERISTICS

CONDENCIAT CL		20	28	35	50	65	75
Compressor	Number	1					
	Type	SCROLL					
	Oil capacity	l	1.1	1.25			1.7
	Oil type	POE					
Refrigerant fluid		R410A					
Refrigerant weight	Kg	1.00			2.00		
Power and intensity Crankcase heater	W/A	45W / 0.2A Optional (1)			45W / 0.2A		
Coil type		Copper tubes - aluminium fins					
Fan	Type	Propeller - direct drive					
	Number	1			2		
	Flow	m <sup>3</sup> /h	2450	2970	5100	5890	5820
	Speed	Rpm	718	897	718	897	
Weight of unit	Kg	64	69	69	101	112	118
Connection	Ø Liquid line	Inches	1/4"	3/8"			1/2"
	Ø Intake line	Inches	1/2"	5/8"	3/4"		7/8"

(1) This option is compulsory if the total refrigerant charge exceeds 4,5 Kg

### ELECTRICAL CHARACTERISTICS

CONDENCIAT CL		20	28	35	50	65	75	
Compressor	Unit nominal voltage	400 V - 3 Ph - 50 Hz						
	Max. intensity	A	4.4	6.9	7.6	10.3	11.2	14.3
Fans	Max. intensity	A	0.47		0.66	0.94	1.32	
Nominal voltage of unit		V	400 V - 3 Ph + N - 50 Hz					
Intensity	A	5.0	7.5	8.3	11.3	12.6	15.7	
Starting intensity	A	27	36	49	65.5	75.5	102.5	
Electrical cables not supplied *	mm <sup>2</sup>	5G1.5		5G2.5	5G4		5G6	
Proximity switch recommended rating	Am	6	10		16		20	

\* cable with 2 or 3 conductors in a raceway or exposed mounting, for temperatures below 60°C, 30 m max. length

**Note :** For other conditions, refer to the norm applied in the country of installation (example for France : NFC 15.100)

### SOUND PRESSURE LEVELS \*\*

CL	20	28	35	50	65	75
Acoustic pressure dB(A)	43	49	49	47	51	51

\*\* at 5m from the unit, 1.5m from the ground, free field, directivity 2.

## DIMENSIONS

### Models 20, 28 and 35

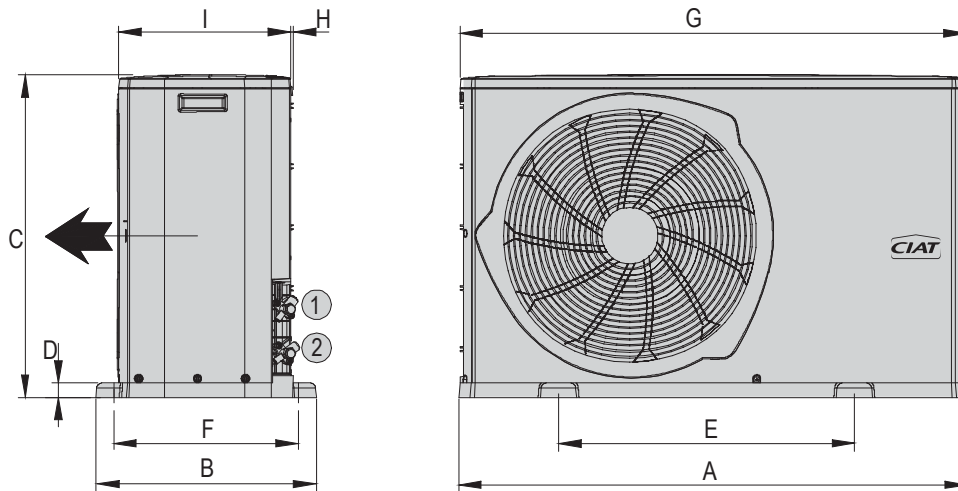

### Models 50, 65 and 75

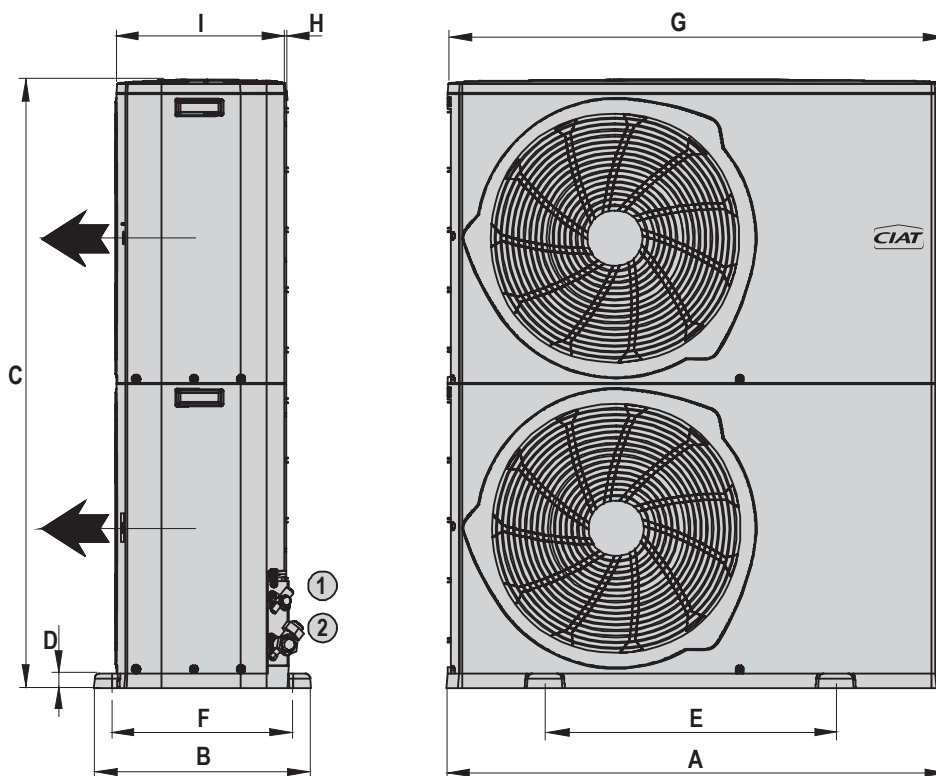

CL	A	B	C	D	E	F	G	H	I
20, 28 and 35	1035	449	658	30	602	375	1030	5	350
50, 65 and 75	1035	449	1258	30	602	375	1030	5	350

- EXTERNAL AIR FLOW
- ① LIQUID LINE
- ② SUCTION GAS LINE

### RECOMMENDATIONS FOR ASSEMBLY

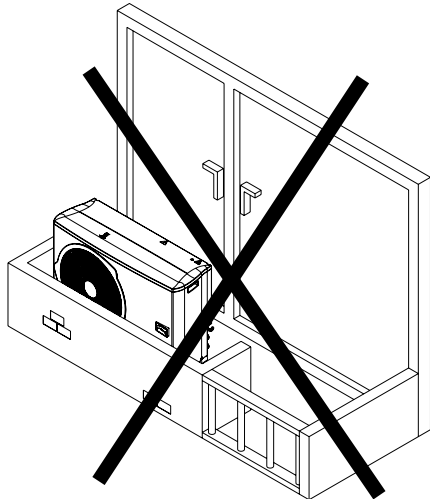
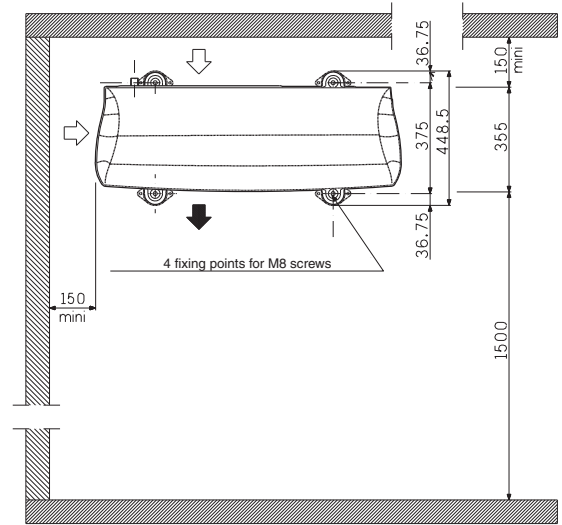
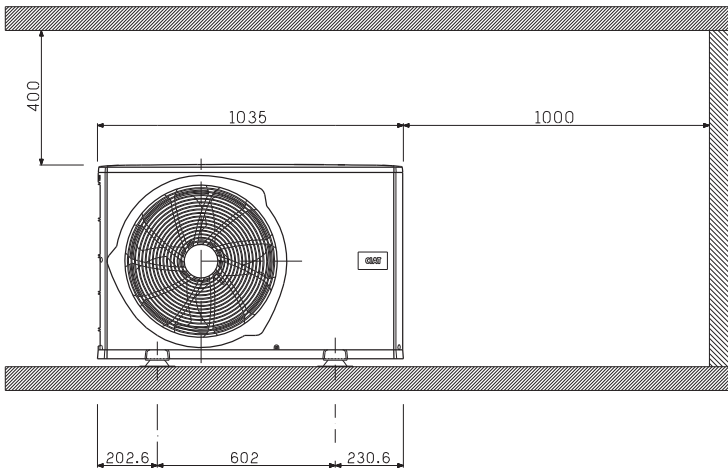

No obstacle should prevent the free air circulation around the **exchange coil** (intake and discharge)

Avoid prevailing winds

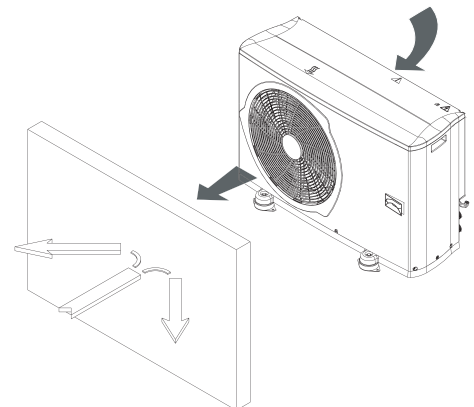

- The external unit must be installed outdoors, on a terrace or in a garden. It has been designed to operate under all types of weather, even adverse conditions, but can also be installed under a 4-side open shelter.
- It is preferable to orientate the unit to the north or place it in the shade, in order to avoid the condenser coil being in direct sunlight.
- Avoid placing obstacles at the fan intake and discharge. There should be no obstacle blocking the coil air intake.

### NOTES

.....

.....

.....

.....

.....

.....

.....

.....

.....

.....



# Condensing units

## NOTES

---

A large area of the page is filled with a grid of small dots, intended for handwritten notes.

This document is non-contractual. As part of its policy of continual product improvement, CIAT reserves the right to make any technical modification it feels appropriate without prior notification.

**Head office**

Avenue Jean Falconnier - B.P. 14  
01350 - Culoz - France  
Tel.: +33 (0)4 79 42 42 42 - Fax: +33 (0)4 79 42 42 10  
info@ciat.fr - www.ciat.com



**CIAT Service**  
Tel.: +33 (0)4 79 42 42 90 - Fax: +33 (0)4 79 42 42 13

CERTIFIED ISO 9001  
QUALITY SYSTEM

